

LOC	DIST	P	LTR	REVISIONS	DATE	BY	APPV
				ÄNDERUNGEN			
				BESCHREIBUNG			
AI	-	E2		DRAWING ISOLATED	20-MAY-03	EW	GF
		F1		PACKAGING MODIFIED, SEALING W/OUT TONGUE	26-AUG-03	EW	GF
		G1		CABLE SCREW JOINT MODIFIED I EGD0-0299-03	13-OCT-03	EW	GF
		H1		CABLE SCREW JOINT, O-RING AND NUT MODIFIED	09-JUN-06	EW	RK

VIEW WITH ASSEMBLED COVER  
 ANSICHT MIT MONTIERTEM DECKEL

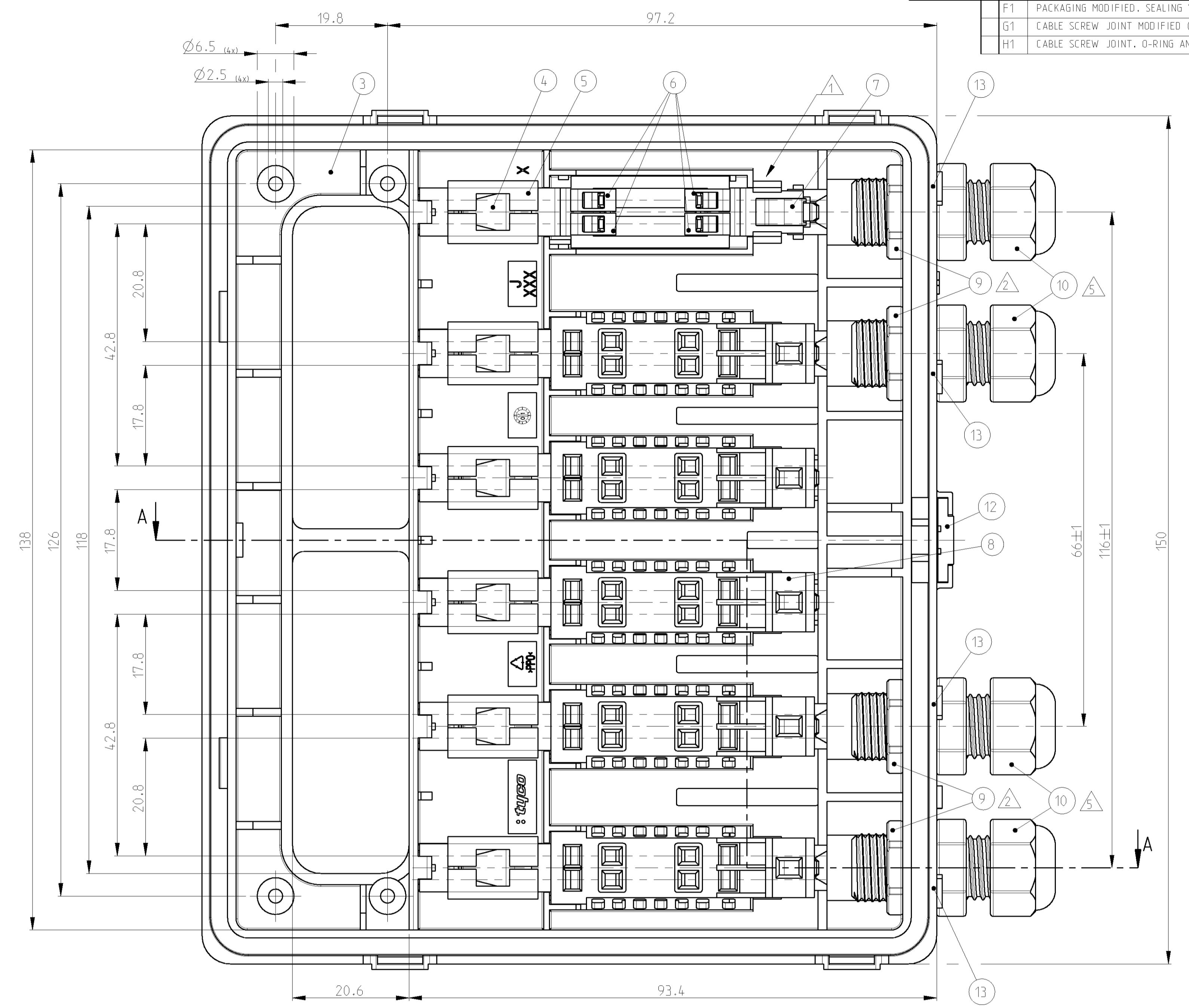
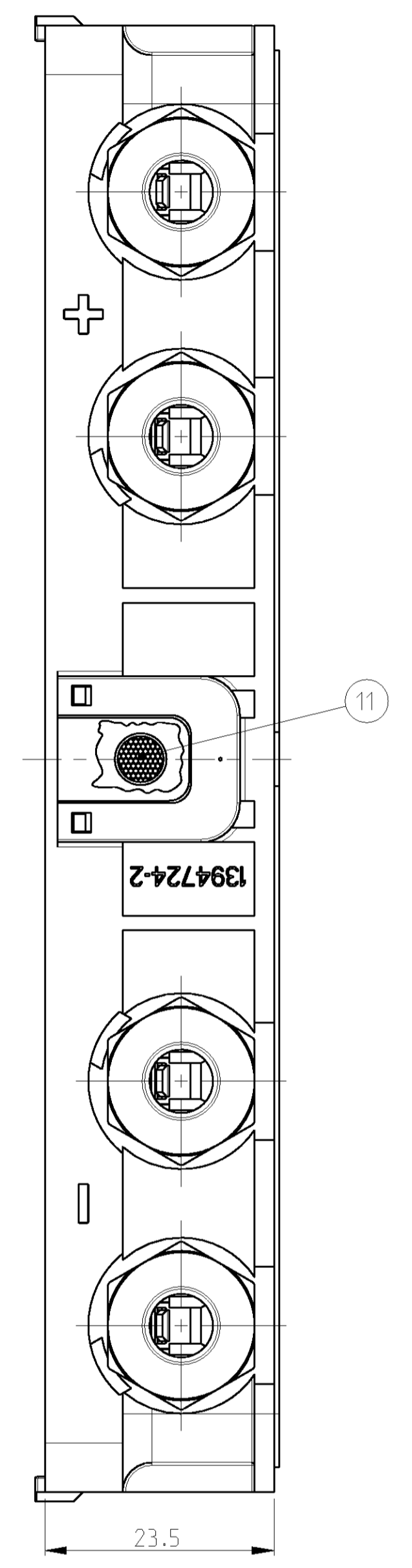
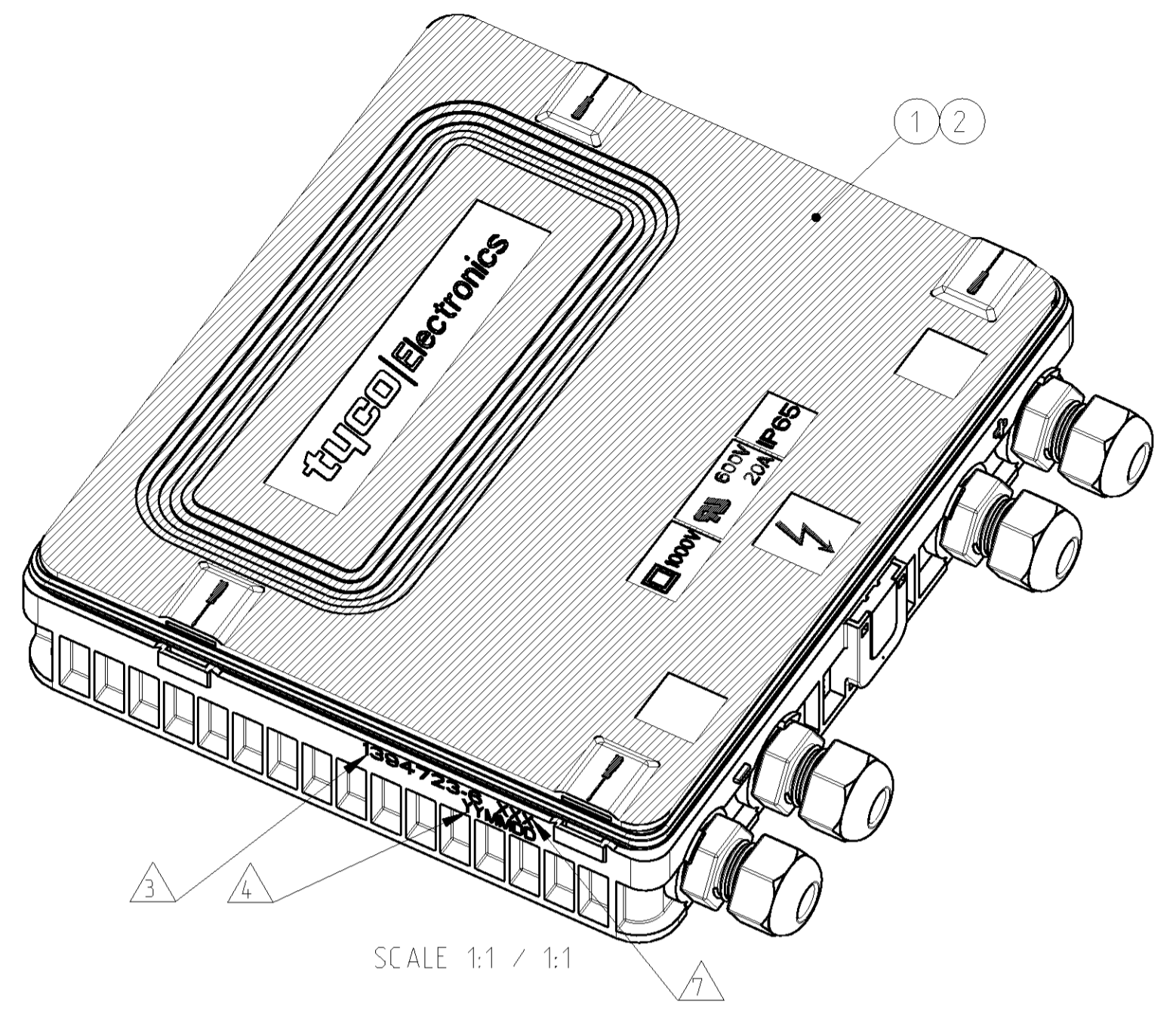

- ▲ ITEM NO. 8 NOT SHOWN
- ▲ TIGHTENING TORQUE FOR NUT  $1.3^{+0.2}$  Nm
- ▲ PART NUMBER
- ▲ PRODUCTION DATE
- ▲ TIGHTENING TORQUE FOR CLAMPING NUT MAX. 1.5 Nm ACCORDING TO THE CABLE SHEATH MATERIAL. HOLD AGAINST WITH TOOL AT CABLE SCREW JOINT.
- ▲ SOLAR MODULE BOX COVER ITEM NO. 1 AND SEALING ITEM NO. 2 NOT SHOWN. COVER NOT ASSEMBLED WITH LOWER PART. ENCLOSE LOOSELY.
- ▲ MANUFACTURING LOCATION CODE

- ▲ POS. 8 NICHT DARGESTELLT
- ▲ ANZUGSDREHMOMENT FÜR MUTTER  $1.3^{+0.2}$  Nm
- ▲ TEILENUMMER
- ▲ FERTIGUNGSDATUM
- ▲ ANZUGSDREHMOMENT FÜR KLEMMUTTER MAX. 1.5 Nm ENTSPRECHEND DEM KABELMANTELMATERIAL. MIT WERKZEUG AN KABELVERSCHRAUBUNG GEGENHALTEN.
- ▲ SOLAR MODUL BOX DECKEL POS. 1 UND DICHTUNG POS. 2 NICHT DARGESTELLT. DECKEL NICHT MIT UNTERTEIL MONTIERT. LOSE BEIGELEGT.
- ▲ FERTIGUNGSSTANDORT-CODE

SECTION A-A  
 SCHNITT A-A

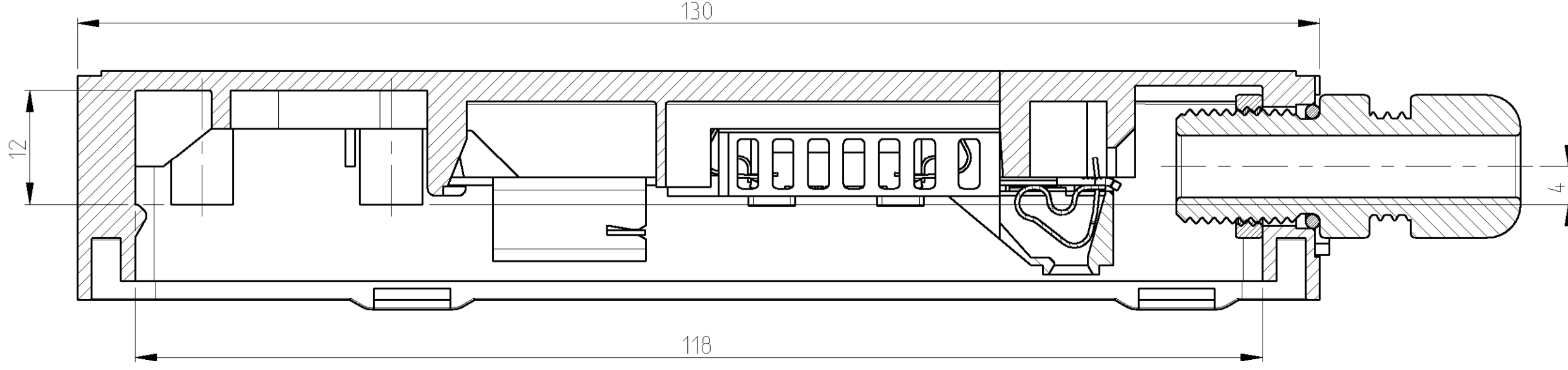

PACKAGING SEE 1394723-1  
 VERPACKUNG SIEHE 1394723-1

-6 AS SHOWN  
 -6 WIE GEZEICHNET

TYCO ORDER NO. / BESTELL-NR.	ITEM-NO. / POS.	QTY. / STK.	DESCRIPTION / BENENNUNG	SURFACE / OBERFLÄCHE / COLOUR/FARBE	MATERIAL
1394723-6	13	4	O-RING / O-RING	-	-
	12	1	COVER / ABDECKUNG	BLACK / SCHWARZ	PPD / PPO
	11	1	FILTER ELEMENT / FILTERELEMENT	-	-
	10	4	CABLE SCREW JOINT / KABELVERSCHRAUBUNG	BLACK / SCHWARZ	PA / PA
	9	4	NUT / MUTTER	ZINC PLATED / VERZINKT	CuZn / CuZn
	8	6	COVER FOR CONTACT RAIL / ABDECKUNG FÜR STROMSCHIENE	BLACK / SCHWARZ	PCT / PCT
	7	6	SPRING CLAMP / ANFESTZUGSPREDER	-	STAINLESS STEEL / ROSTFREIER STAHL
	6	24	AMP SPRING CLAMP WITH ANTI OVERSTRESS / AMP-ANFESTZUGSPREDER MIT OBERBEHNSCHUTZ	PLAIN / BLANK	STAINLESS STEEL / ROSTFREIER STAHL
	5	6	CONTACT RAIL / STROMSCHIENE	PRESILVER / VORVERSLIBERT	CuMo / CuMo
	4	6	FOIL SPRING / FOLIENFEDER	PLAIN / BLANK	STAINLESS STEEL / ROSTFREIER STAHL
	3	1	SOLAR MODULE BOX LOWER PART, 4 POS. / SOLAR MODUL BOX UNTERTEIL, 4-FACH	BLACK / SCHWARZ	PPD / PPO
	2	1	SEALING RADIAL SEAL / DICHTUNG RADIALDICHT	BLACK / SCHWARZ	PP/EPDM / PP/EPDM
	1	1	SOLAR MODULE BOX COVER / SOLAR MODUL BOX DECKEL	BLACK / SCHWARZ	PPD / PPO

TYCO ORDER NO. / BESTELL-NR.	ITEM-NO. / POS.	QTY. / STK.	DESCRIPTION / BENENNUNG	SURFACE / OBERFLÄCHE / COLOUR/FARBE	MATERIAL
1394723-6	13	4	O-RING / O-RING	-	-
1394723-6	12	1	COVER / ABDECKUNG	BLACK / SCHWARZ	PPD / PPO
1394723-6	11	1	FILTER ELEMENT / FILTERELEMENT	-	-
1394723-6	10	4	CABLE SCREW JOINT / KABELVERSCHRAUBUNG	BLACK / SCHWARZ	PA / PA
1394723-6	9	4	NUT / MUTTER	ZINC PLATED / VERZINKT	CuZn / CuZn
1394723-6	8	6	COVER FOR CONTACT RAIL / ABDECKUNG FÜR STROMSCHIENE	BLACK / SCHWARZ	PCT / PCT
1394723-6	7	6	SPRING CLAMP / ANFESTZUGSPREDER	-	STAINLESS STEEL / ROSTFREIER STAHL
1394723-6	6	24	AMP SPRING CLAMP WITH ANTI OVERSTRESS / AMP-ANFESTZUGSPREDER MIT OBERBEHNSCHUTZ	PLAIN / BLANK	STAINLESS STEEL / ROSTFREIER STAHL
1394723-6	5	6	CONTACT RAIL / STROMSCHIENE	PRESILVER / VORVERSLIBERT	CuMo / CuMo
1394723-6	4	6	FOIL SPRING / FOLIENFEDER	PLAIN / BLANK	STAINLESS STEEL / ROSTFREIER STAHL
1394723-6	3	1	SOLAR MODULE BOX LOWER PART, 4 POS. / SOLAR MODUL BOX UNTERTEIL, 4-FACH	BLACK / SCHWARZ	PPD / PPO
1394723-6	2	1	SEALING RADIAL SEAL / DICHTUNG RADIALDICHT	BLACK / SCHWARZ	PP/EPDM / PP/EPDM
1394723-6	1	1	SOLAR MODULE BOX COVER / SOLAR MODUL BOX DECKEL	BLACK / SCHWARZ	PPD / PPO